

1.

In which type of climate does chemical weathering usually occur most rapidly?

- 1. hot and dry
- 2. hot and wet
- 3. cold and dry
- 4. cold and wet

2.

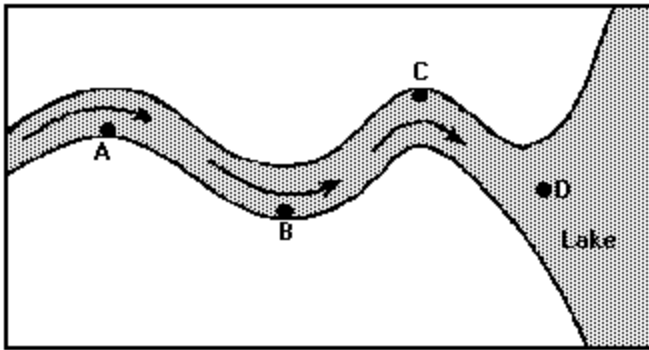

Figure 1

The map shows the top view of a meandering stream as it enters a lake. At which points along the stream are erosion and deposition dominant?

- 1. Erosion is dominant at *A* and *D*, and deposition is dominant at *B* and *C*.
- 2. Erosion is dominant at *B* and *C*, and deposition is dominant at *A* and *D*.
- 3. Erosion is dominant at *A* and *C*, and deposition is dominant at *B* and *D*.
- 4. Erosion is dominant at *B* and *D*, and deposition is dominant at *A* and *C*.

3.

The particles in a sand dune deposit are small and very well-sorted and have surface pits that give them a frosted appearance. This deposit most likely was transported by

- 1. ocean currents
- 2. glacial ice
- 3. gravity
- 4. wind

Review 1

4.

Which geologic evidence would best support the inference that a continental ice sheet once covered a given location?

- | | |
|--|---|
| 1. polished and smooth pebbles; meandering rivers;
V-shaped valleys | 3. sand and silt beaches; giant swamps; marine fossils
found on mountaintops |
| 2. scratched and polished bedrock; unsorted gravel
deposits; transported boulders | 4. basaltic bedrock; folded, faulted, and tilted rock
structures; lava flows |

5.

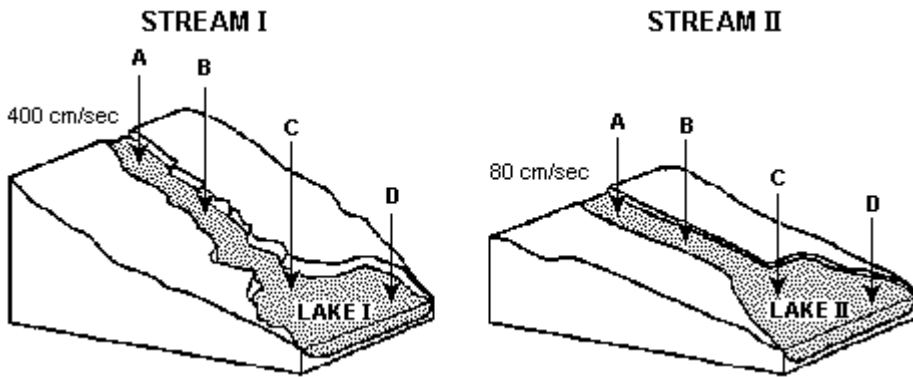

Figure 2

A mixture of colloids, clay, silt, sand, pebbles, and cobbles is put into stream I at point A. The water velocity at point A is 400 centimeters per second. A similar mixture of particles is put into stream II at point A. The water velocity in stream II at point A is 80 centimeters per second. Which statement best describes what happens when the particles are placed in the stream?

- | | |
|---|--------------------------------|
| 1. Stream I will move all particles that are added at point A. | 3. Stream I cannot move sand. |
| 2. Stream II will move all particles that are added at point A. | 4. Stream II cannot move sand. |

Review 1

6.

[Refer to figure 2 in question 5]

A mixture of colloids, clay, silt, sand, pebbles, and cobbles is put into stream I at point A. The water velocity at point A is 400 centimeters per second. A similar mixture of particles is put into stream II at point A. The water velocity in stream II at point A is 80 centimeters per second. If a sudden rainstorm occurs at both streams above point A, the erosion rate will

1. increase for stream I, but not for stream II
2. increase for stream II, but not for stream I
3. increase for both streams
4. not change for either stream

7.

[Refer to figure 2 in question 5]

A mixture of colloids, clay, silt, sand, pebbles, and cobbles is put into stream I at point A. The water velocity at point A is 400 centimeters per second. A similar mixture of particles is put into stream II at point A. The water velocity in stream II at point A is 80 centimeters per second. In lake I, as the stream water moves from point C to point D, its velocity

1. decreases
2. increases
3. remains the same

Review 1

8.

To investigate the effects of abrasion on limestone rock chips, students placed rock chips of uniform size and shape in jars half-filled with water and shook them for different lengths of time. One rock chip was collected for each length of shaking time and these chips were arranged in a display. Which column below shows the rock chips arranged from top to bottom in order of least to most shaking time?

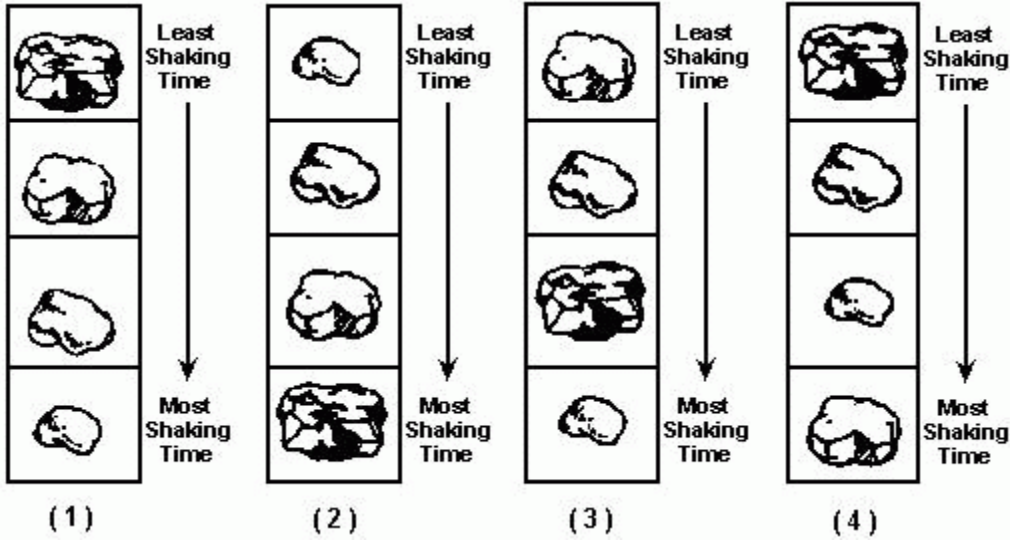

9.

Transported sediments are usually deposited at locations in which

1. the freezing and thawing of water occurs
2. the chemical breakdown of rocks occurs
3. a decrease in the speed of the agent of erosion occurs
4. an increase in the physical weathering of rocks occurs

10.

Compared to a low-density spherical particle, a high-density spherical particle of the same size will sink through water

1. more slowly
2. more rapidly
3. at the same rate
4. density is not a factor in the settling rate of a particle

11.

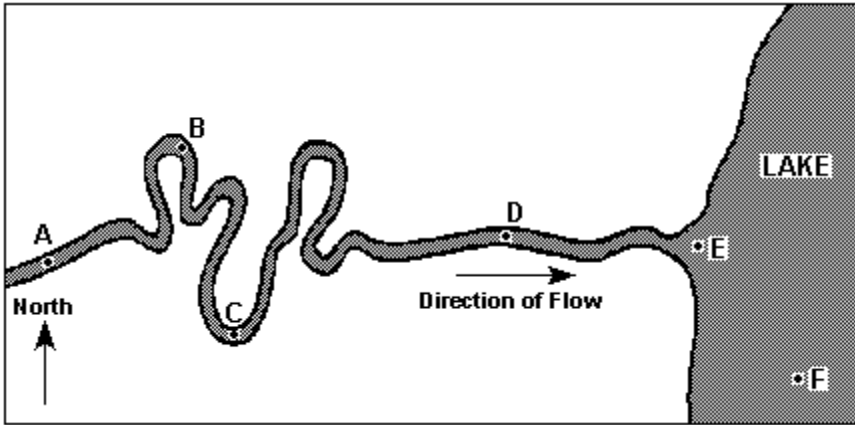
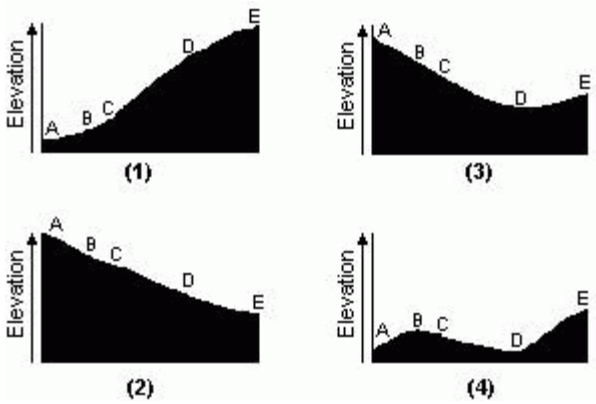

Figure 3

The map shows a stream flowing into a lake. Letters *A* through *F* represent locations in the stream and lake. Which diagram best represents the change in the stream's elevation from location *A* to *E*?



Review 1

12.

[Refer to figure 3 in question 11]

The map shows a stream flowing into a lake. Letters *A* through *F* represent locations in the stream and lake. Which diagram best represents the cross section of the stream at location *C*? [Note that letters **N** and **S** represent the north and south sides of the stream.]

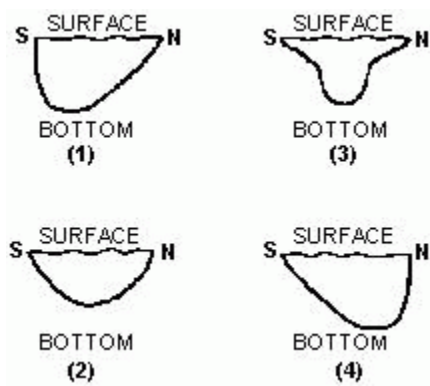

13.

[Refer to figure 3 in question 11]

The map shows a stream flowing into a lake. Letters *A* through *F* represent locations in the stream and lake. Where would the greatest amount of sediments most likely be deposited by this stream?

- 1. *E* 3. *F*
- 2. *B* 4. *D*

14.

[Refer to figure 3 in question 11]

The map shows a stream flowing into a lake. Letters *A* through *F* represent locations in the stream and lake. Which kind of sediment would probably be deposited farthest out in the lake?

- 1. sand 3. clay
- 2. silt 4. pebbles

Review 1

15.

[Refer to figure 3 in question 11]

The map shows a stream flowing into a lake. Letters *A* through *F* represent locations in the stream and lake. The velocity of this stream at point *B* depends on the stream's

- 1. slope, only
- 2. discharge, only
- 3. slope and discharge, only
- 4. slope, discharge, and channel shape

16.

Particles of soil often differ greatly from the underlying bedrock in color, mineral composition, and organic content. Which conclusion about these soil particles is best made from this evidence?

- 1. They are residual sediments.
- 2. They are transported sediments.
- 3. They are uniformly large-grained.
- 4. They are soluble in water.

17.

Which graph below best represents the relationship between stream erosion and the kinetic energy of a stream?

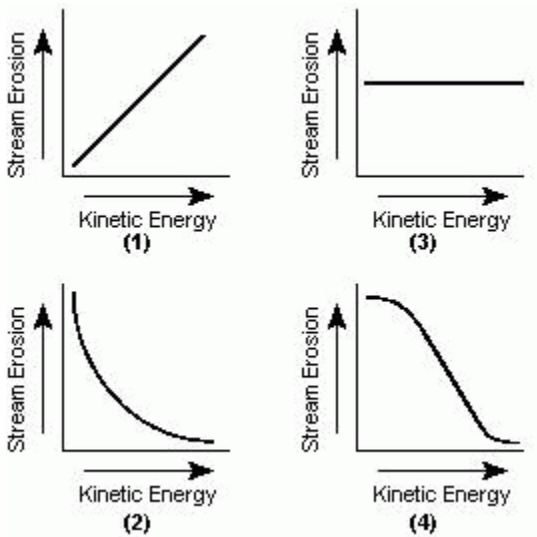

18.

A river carrying pebbles, sand, silt, and clay flows into the ocean. The sediments are sorted by size as they are deposited at different distances from shore. Which sedimentary rock will most likely form from the sediment deposited farthest from shore?

- 1. conglomerate
- 2. sandstone
- 3. siltstone
- 4. shale

19.

Mineral	Color	Luster	Streak	Hardness	Density (g/mL)	Chemical Composition
biotite mica	black	glassy	white	soft	2.8	$K(Mg,Fe)_3(AlSi_3O_{10})(OH)_2$
diamond	varies	glassy	colorless	hard	3.5	C
galena	gray	metallic	gray-black	soft	7.5	PbS
graphite	black	dull	black	soft	2.3	C
kaolinite	white	earthy	white	soft	2.6	$Al_2(Si_2O_5)(OH)_4$
magnetite	black	metallic	black	hard	5.2	Fe_3O_4
olivine	green	glassy	white	hard	3.4	$(Fe,Mg)_2SiO_4$
pyrite	brass yellow	metallic	greenish-black	hard	5.0	FeS_2
quartz	varies	glassy	colorless	hard	2.7	SiO_2

Figure 4

The table shows the physical properties of nine minerals. Which mineral would most likely be changed most after being placed in a container and shaken for 10 minutes?

- 1. pyrite
- 2. quartz
- 3. magnetite
- 4. kaolinite

This answer should be 3.

20.



Figure 5

The photograph shows a fan-shaped accumulation of sediment. This accumulation of sediment is the direct result of

1. weathering of bedrock
2. erosion by wind
3. deposition by running water
4. transport by glaciers

21.

When minerals are dissolved, how are the resulting ions carried by rivers?

1. by precipitation
2. by tumbling and rolling
3. in suspension
4. in solution

22.

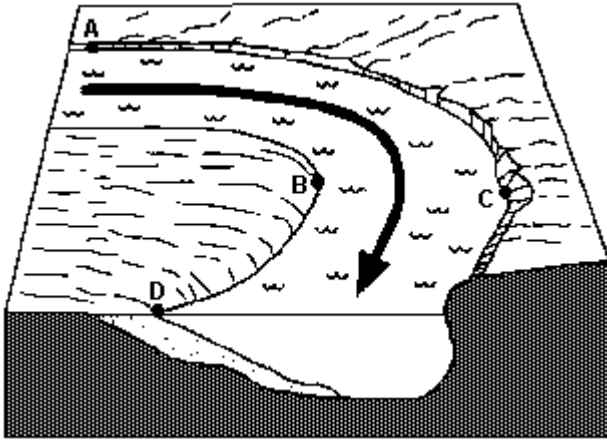

Figure 6

In the diagram, the arrow shows the direction of the stream flow around the bend. At which point does the greatest stream erosion occur?

- 1. *A* 3. *C*
- 2. *B* 4. *D*

23.

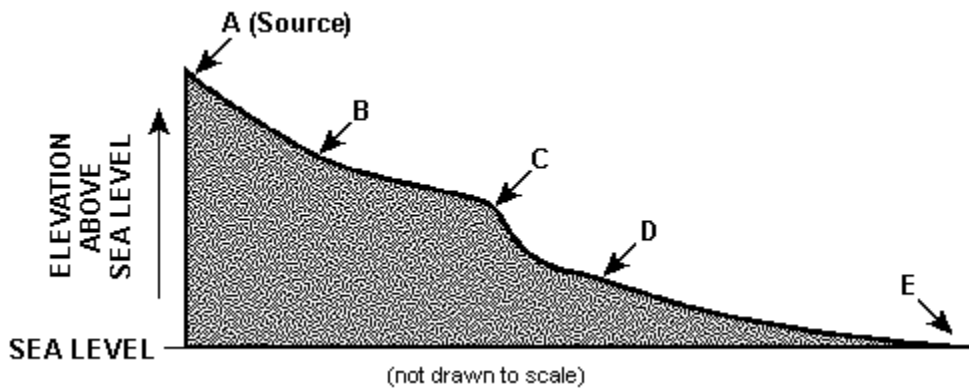

Figure 7

The diagram represents a profile of a stream. Points *A* through *E* are locations along the stream. The primary force responsible for the flow of water in this stream is

- 1. solar energy 3. wind
- 2. magnetic fields 4. gravity

This answer should be 3.

24.

[Refer to figure 7 in question 23]

The diagram represents a profile of a stream. Points *A* through *E* are locations along the stream. Between which two points is potential energy changing to kinetic energy most rapidly?

- 1. *A* and *B*
- 2. *B* and *C*
- 3. *C* and *D*
- 4. *D* and *E*

25.

Sample	Settling Time (seconds)
<i>A</i>	13.10
<i>B</i>	13.75
<i>C</i>	13.50

Figure 8

The data table shows the results of an activity in which three samples of copper (*A*, *B*, and *C*) of equal mass were timed as they settled to the bottom of a column of water. The differences in the settling time of the three samples are probably due to differences in their

- 1. density
- 2. composition
- 3. color
- 4. shape

26.

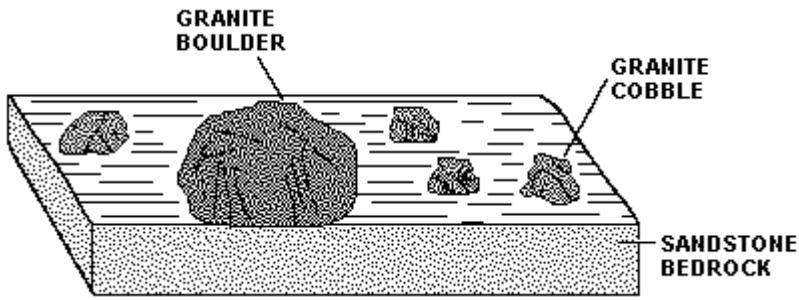

Figure 9

The diagram shows a surface and cross-sectional view of a portion of Earth 15 kilometers from a mountain range. The best explanation for the presence of an isolated boulder in this location is that the boulder was

1. eroded from a limestone cliff
2. transported there by a glacier
3. placed there by a volcanic eruption
4. deposited there by a slow-moving stream

27.

To compare the velocities of different parts of a stream, five similar floating objects are placed in the stream at points A through E at Station 1. If the five objects are released at the same time, what is the most probable arrangement of the objects as they approach Station 2?

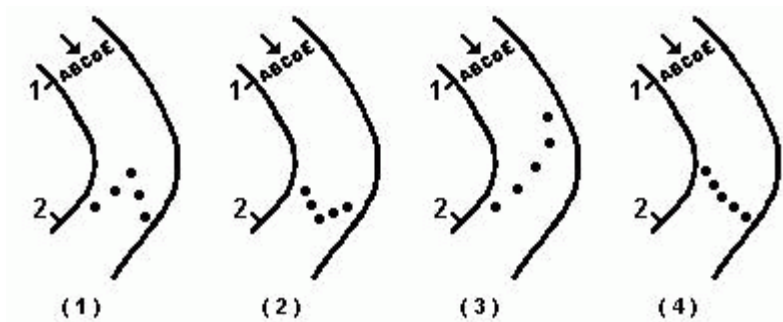

28.

Type of Particles	Total Mass of Particles	Total Volume of Particles
<i>A</i>	120 g	20 cm ³
<i>B</i>	120 g	30 cm ³
<i>C</i>	120 g	40 cm ³
<i>D</i>	120 g	60 cm ³

Figure 10

Four types of particles, *A*, *B*, *C*, and *D*, all of equal size and shape, were mixed together and dropped into a column of water. The data table lists the total mass and volume of each type of particle. Which diagram best represents how the particles would appear in the bottom of the column of water after all of them have settled?

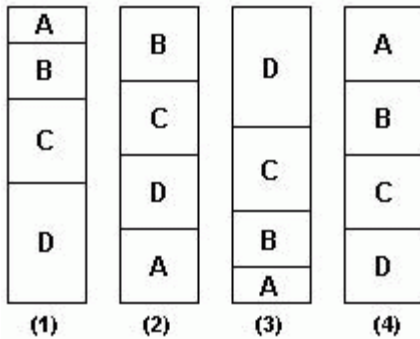

29.

On earth, the predominate agent of erosion is

1. wave action
2. moving ice
3. running water
4. moving air

30.

Which statement presents the best evidence that a boulder-sized rock is an erratic?

1. The boulder has a rounded shape.
2. The boulder is larger than surrounding rocks.
3. The boulder differs in composition from the underlying bedrock.
4. The boulder is located near potholes.

31.

The direction of movement of a glacier is best indicated by the

- 1. elevation of erratics
- 2. alignment of grooves in bedrock
- 3. size of kettle lakes
- 4. amount of deposited sediments

32.

With the new reference tables, the best answer for this question would be 2.

According to the graph of the *Relationship of the Particle Size to Water Velocity* in the reference information, what is the minimum stream velocity needed to maintain transport of a pebble that is 1 centimeter in diameter?

- 1. 23 cm/sec
- 2. 50 cm/sec
- 3. 75 cm/sec
- 4. 100 cm/sec

33.

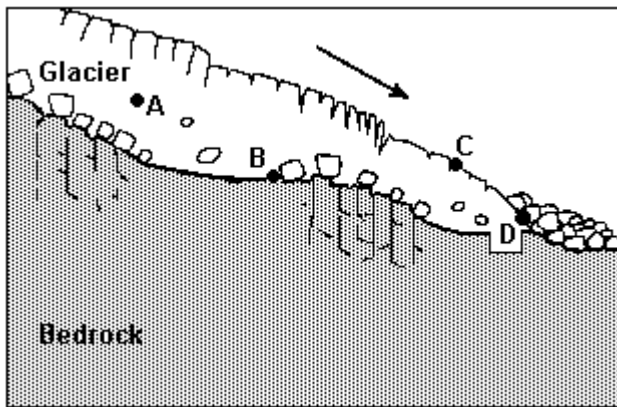

Figure 11

The cross section represents the transport of sediments by a glacier. At which location is deposition most likely the dominant process?

- 1. A
- 2. B
- 3. C
- 4. D

34.

Which type of climate has the greatest amount of rock weathering caused by frost action?

1. a dry climate in which temperatures remain below freezing
2. a dry climate in which temperatures alternate between below freezing to above freezing
3. a wet climate in which temperatures remain below freezing
4. a wet climate in which temperatures alternate between below freezing to above freezing

35.

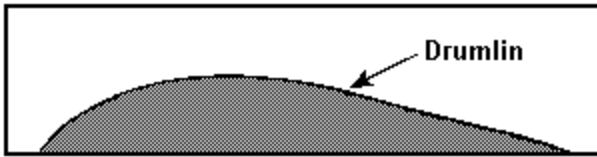

Figure 12

The diagram represents a side view of a hill (drumlin) that was deposited by a glacier . This hill is most likely composed of

1. cemented sediments
2. unsorted sediments
3. vertically layered sediments
4. horizontally layered sediments